

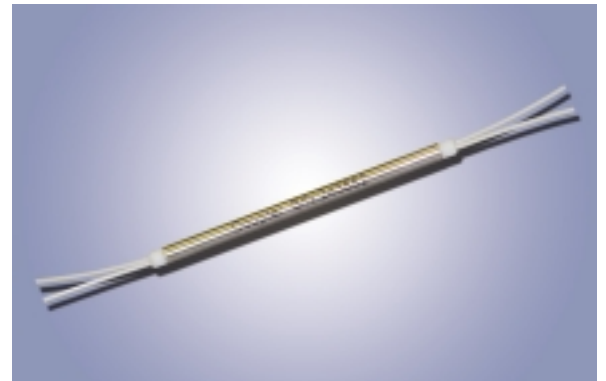

Opto-Link  
Corporation Ltd

## Single Mode Filter Couplers

Single Mode Filter Couplers are used to distribute optical signals between fibers. We offer various types of single mode coupler including standard couplers, polarization independent couplers, filter couplers, wavelength independent couplers and wavelength flattened couplers. These couplers are highly stable. They have low insertion loss, low polarization sensitivity and excellent uniformity.



### Types

- Single Mode **Standard** Couplers
- Single Mode **Polarization Independent** Couplers
- Single Mode **Wavelength Independent** Couplers
- Single Mode **Wavelength Flattened** Couplers
- Single Mode **Filter** Couplers

### Applications

- Long Haul Telecommunications
- Test Equipment
- CATV System
- Fiber Optic Sensors
- Network Monitoring
- LAN, WAN Systems
- Subscribers Loop

### Features

- Ultra Low Insertion Loss
- Ultra Low Polarization Sensitivity
- Dual-Window
- Various Coupling Ratio
- Wide Bandwidth
- Environmentally Stable
- Excellent Uniformity



Opto-Link  
Corporation Ltd

## SPECIFICATIONS

### Single Mode Filter Couplers (1310nm or 1550nm)

Parameter	Values	Units
Center Wavelength	1310 or 1550	nm
Operating Wavelength Range	+/-40	nm
Configuration	1x2	--
Max. Excess Loss	1.0	dB
Max. Uniformity	0.6	dB
Tap Ratio	50%	%
Min. Return Loss	50	dB
Max. Optical Power (Continuous Wave)	300	mW
Max. Tensile Load	5	N
Operating Temperature	-5 to +70	°C
Storage Temperature	-40 to +85	°C
Fiber Type	DSF fiber	--

\*IL is 0.3dB higher, and RL is 5dB lower for each connector added.

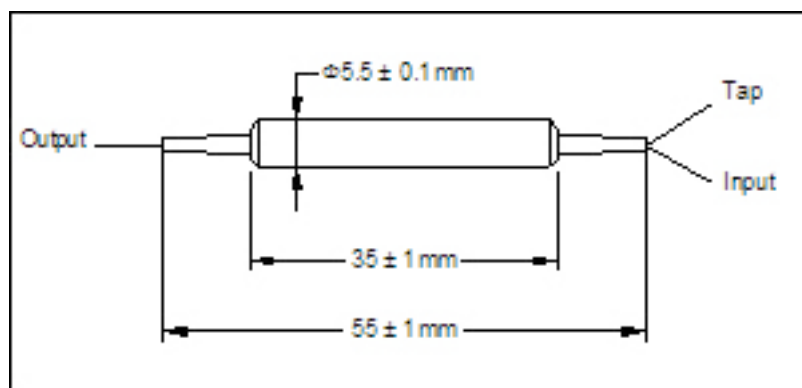

## ORDERING CODES

OLCPL - S - T - [ ] - [ ] - [ ] - [ ] - [ ]

Wavelength	Code
1310 nm	131
1550 nm	155

Connector Type	Code
No Connector	NC
FC/PC	FP
FC/APC	FA
SC/APC	SA
Others	XX

Port	Code
1 x 2	12
2 x 2	22

Coupling Ratio	Code
10/90	10
20/80	20
30/70	30
40/60	40
50/50	50

Lead Types	Code
900 $\mu$ m loose tube	90
250 $\mu$ m bare fiber	25
3 mm loose cable	3

■ Opto-Link Corporation Ltd. reserves the right to make changes to the products described herein without notice.

COPYRIGHT © 2002-2008 Opto-Link Corporation Ltd.

Tel: +852 2480-6106 Fax: +852 2480-1621 Email: [contact@optolinkcorp.com](mailto:contact@optolinkcorp.com) Website: [www.optolinkcorp.com](http://www.optolinkcorp.com)